



EPRO

PRODUKTKATALOG

PRODUCT CATALOG | CATALOGUE DES PRODUITS



We make bottles.

2025
2026



EPROPLAST GmbH

An der Asbacher Str. 38
98574 Schmalkalden
Germany

Tel: +49 3683 4071-0
Fax: +49 3683 4071-130
Mail: info@eproplast.com

WWW.EPROPLAST.COM

We make bottles.

PRODUKTE

RUNDFLASCHEN

ROUND BOTTLES
BOUTEILLES RONDES

Seite 18 - 27

TALL BOSTON ROUND	19
BOSTON ROUND EDGE	19
BOSTON ROUND	20
EPROSHARP	20
EPROTUBE	21
EPROVERA	21
EPROCARE	22
OPTIMAX	22
CATCH	22
EPROPHARM	23
EPROALPHA	23
TUBO ROUND	24
EPROBALL	24
ROUND FIRE	24
TECHNO ROUND	25
EPROFUEL	25
E-LISMOKE	25
EPROFOAM	26
EPROGEWÜRZ	26
PET PACKER	26
EPROJAR	27

OVALFLASCHEN

OVAL BOTTLES
BOUTEILLES OVALES

Seite 28 - 35

BASIC OVAL	29
EPROCARE OVAL	29
DOMO	29
EPOVAL	30
SHORT OVAL	30
EPOCLEAN	30
OPTIVAL	31
E-MAGIC	31
CONE	31
APOTHEKERFLASCHE	32
EPROMOWA	32
FAMILY	32
SQUEEZI-A	33
SQUEEZI-SLIM	33
SQUEEZI-KOS	33
POCKET SQUEEZE	34
MINI SQUEEZE	34

RECHTECKFLASCHEN

RECTANGULAR BOTTLES
BOUTEILLES RECTANGULAIRES

Seite 36 - 39

EPROSQUARE	37
EPROSQAURE FLAT	37
EPROSWING	37
EPROFOAM SQUARE	38
EPROKANISTER	38



SPRÜHFLASCHEN

TRIGGER SPRAY BOTTLES
VAPORISATEURS

Seite 40 - 45

KEULENFLASCHE	41
WEIMAR	41
OCEAN	42
POTSDAM	42
JENA	42
ROSTOCK	43
STRALSUND	43
BOSTON ROUND	43
EPROVERA	44
DESSAU	44

FLASCHEN FÜR KALTABFÜLLUNG

BOTTLES FOR COLD FILL
BOUITEILLES POUR REMPLISSAGE À FROID

Seite 46 - 53

EPROJUICE	47
EPROJUICE SQUARE	47
EPROJUICE-R	48
EPROJUICE WAVE	48
EPROROUND	49
EPROSLIM	49
SQUEEZI-HONIG	50
SQUEEZI-BEE	50
HONIGWABEN	51
HONIG-SLIM	51
SQUEEZI-A	51
SQUEEZI-WAVE	52
HONEY OVAL	52
SQUEEZER OVAL	52
EPROWEIN	53
TASCHENFLASCHE	53
DELI 300	53

FLASCHEN FÜR HEISSABFÜLLUNG

BOTTLES FOR HOT FILL
BOUITEILLES POUR REMPLISSAGE À CHAUD

Seite 54 - 63

- PANELLESS -	EPROJUICE HF	59
	TRANSWAVE HF	59
	E-SMOOTH HF	59
	EPRORINGFLASCHE HF	60
	PANEL-A HF	60
	DELI HF	60
	SQUEEZER OVAL HF	61
	MAPLE CLAD SLIM HF	61
	MAPLE CLAD WIDE HF	61
	MAPLE RIBS HF	62
- STANDARD -		

INDIVIDUELLE KUNDENFLASCHEN

CUSTOMIZED BOTTLE DESIGN
FORMES DE CLIENTS INDIVIDUELLES

Seite 16 - 17

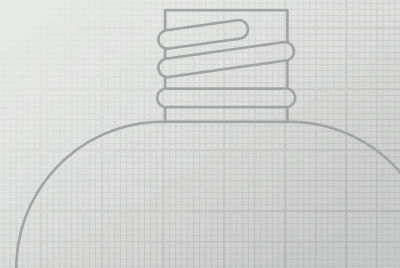

VERSCHLÜSSE

CLOSURES
BOUCHONS

Seite 64 - 67



PREFORMS

PREFORMS
PRÉFORMES

Seite 68 - 69



UNTERNEHMEN

THE COMPANY

L'ENTREPRISE

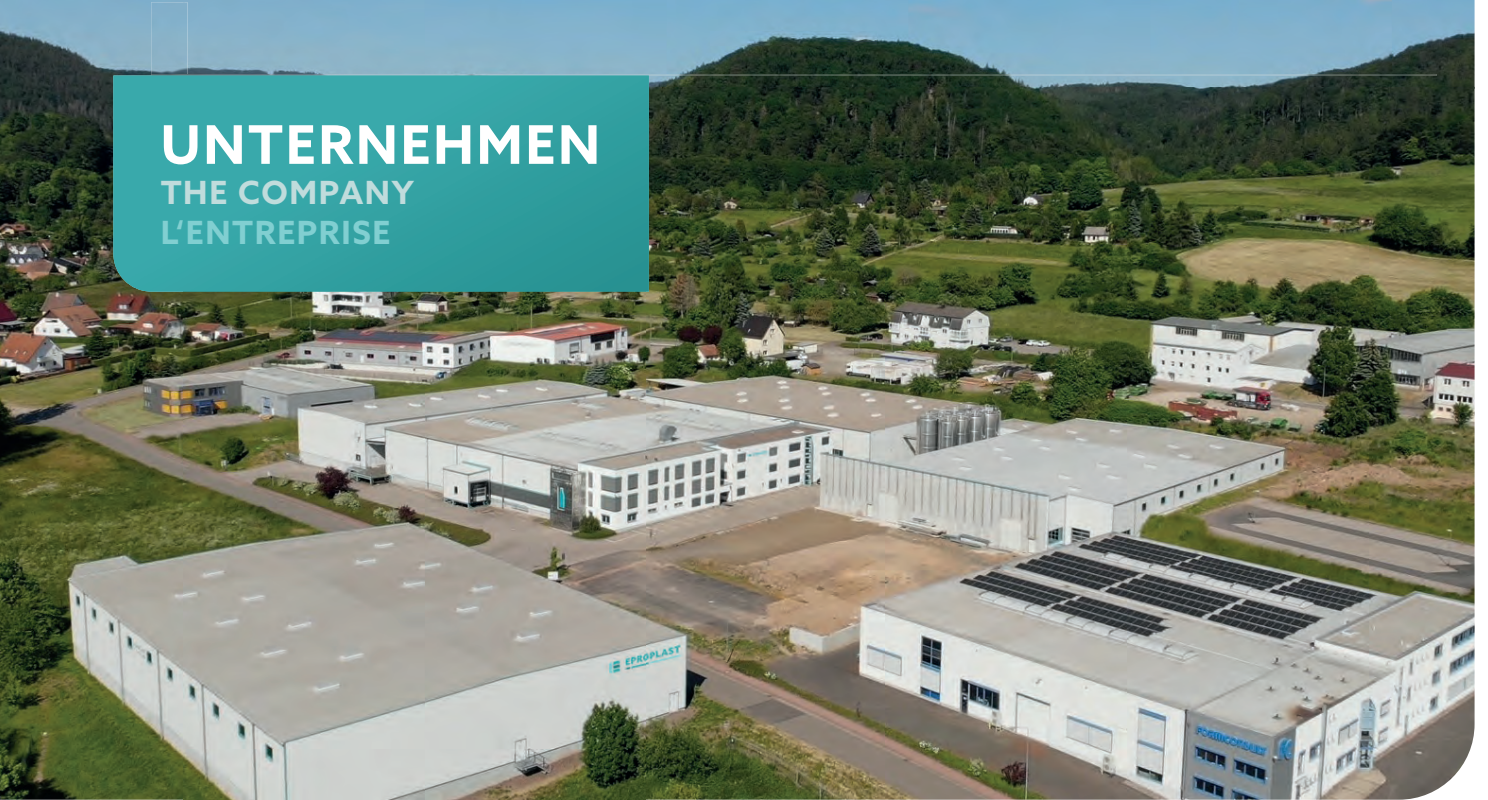

Als mittelständisches Unternehmen sind wir spezialisiert auf die Entwicklung und Produktion von PET-Verpackungen. Neben einem breiten Angebot an frei verfügbaren Standardflaschen besteht der Schwerpunkt unserer Aktivitäten in der Entwicklung und Produktion von individuellen Kundenflaschen.

As a medium sized enterprise we are specialized in the development and production of PET-packaging. Besides a wide range of free available standard bottles, the centre points of our activities are the development and the production of individual designed customized bottles.

En tant que PME, nous nous sommes spécialisés dans le développement et la production d'emballages en PET. Outre une large gamme de bouteilles standard librement disponibles, l'axe essentiel de nos activités consiste à développer et à produire des bouteilles personnalisées pour nos clients.

DESIGN, ENTWICKLUNG & FORMENBAU

DESIGN, DEVELOPMENT & MOULD MAKING

DESIGN, DEVELOPPEMENT & FABRICATION DE MOULE

One-stop shopping - Wir bieten für unsere Kunden die komplette Dienstleistung von der **Designentwicklung über die Konstruktion bis zum Formenbau** aus einer Hand. Durch unser modulares Formenkonzept ECO-SHELL können wir individuelle Formen zu einem günstigen Preis und mit kurzen Lieferzeiten anbieten.

One-stop shopping - we offer a complete service consisting of: **bottle development & design, mould design, mould making & production** out of a single source. Due to our modular mould concept ECO-SHELL we are able to offer individual moulds for a low price with short delivery time.

Tout clés en main: Nous offrons à nos clients une prestation complète regroupant: **le développement du Design, la construction & Fabrication de moule**. Grâce à notre concept de moules modulaires ECO-SHELL, nous sommes en mesure de vous proposer des prix intéressants avec de courts délais de livraison.

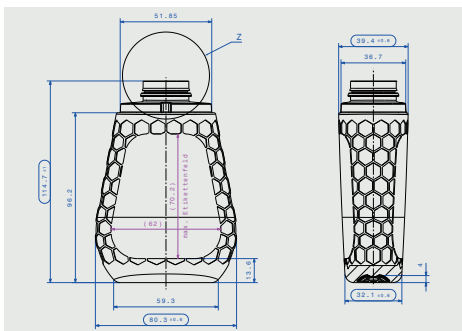

PRODUKTION

PRODUCTION
FABRICATION



Flaschenproduktion

PET Preforms und Flaschen werden auf modernsten Anlagen produziert. Es werden überwiegend sog. 2-Stufen-Streck-Blasanlagen eingesetzt. Bei dieser Anlagentechnik ist es möglich, die beiden Produktionsprozesse unabhängig voneinander zu optimieren.

PET preforms and bottles are produced with state of the art production equipment. Predominately two stage stretch blow moulding equipment is utilized. With this kind of technique it is possible to optimize the both production processes independently from each other.



Preform in Blasmachine

Les préformes et bouteilles en PET sont produites avec des équipements de production de pointe. Il y a principalement 2 étapes appelées Éirage soufflage. Avec ce type de technique il est possible d'optimiser les deux processus de production indépendamment l'un de l'autre.

PET - DAS MATERIAL

PET - THE MATERIAL
LE MATÉRIAU - PET

Barriereigenschaften PET vs. PP & HDPE
barrier propriétés PET vs. PP & HDPE
propriétés barrières PET vs. PP & HDPE



PET Neuware Granulat

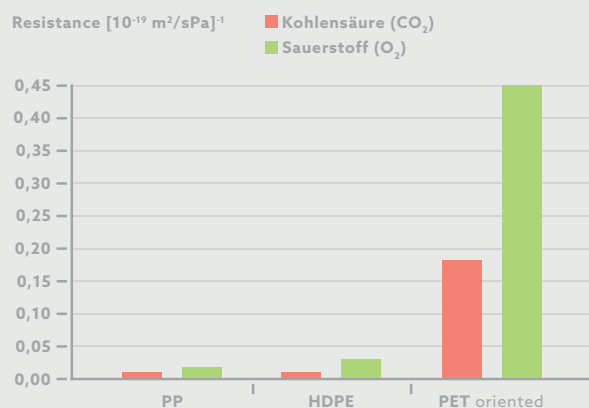

Vergleich Barriereigenschaften

Die Barriereeigenschaft von PET gegen Entweichen von Kohlendioxid (CO₂) oder Eindringen von Sauerstoff (O₂) ist im Vergleich zu PP (Polypropylen) und HDPE (High Density Polyethylen) um ein Vielfaches besser. Durch den Einsatz von Additiven können die Barriereigenschaften noch einmal zusätzlich verbessert werden.

In comparison to other polymers such as polypropylene (PP) and high-density polyethylene (HDPE) the barrier property of PET is much better. Due to the use of additives such as Scavenger the barrier property against oxygen can be improved additionally.

La propriété de barrière du PET contre la fuite de gaz carbonique (CO₂) ou la pénétration de l'oxygène (O₂) est bien meilleure à celle du PP (polypropylène) et PEHD (polyéthylène haute densité). Grâce à l'utilisation de d'additifs, ces propriétés de barrière peuvent être encore une fois améliorées.

QUALITÄTSMANAGEMENT / HYGIENEMANAGEMENT

QUALITY MANAGEMENT / INDUSTRIAL HYGIENE MANAGEMENT

GESTION DE LA QUALITE / GESTION DE DE L'HYGIENE

EPROPLAST ist nach DIN EN ISO 9001:2008 und 50001:2011 zertifiziert. Ebenfalls sind wir nach einem der wichtigsten Lebensmittelverpackungsstandards FSSC22000 (Food Safety System Certification 22000) zertifiziert.

EPROPLAST is certified according to DIN ISO 9001:2008 and 50001:2011. Also we are certified according to one of the most important food packaging standards FSSC22000 (Food Safety System Certification 22000).

EPROPLAST est certifié DIN EN ISO 9001:2008 et 50001:2011. Nous sommes également certifiés selon l'une des normes d'emballage alimentaire les plus importantes FSSC22000 (Food Safety System Certification 22000).

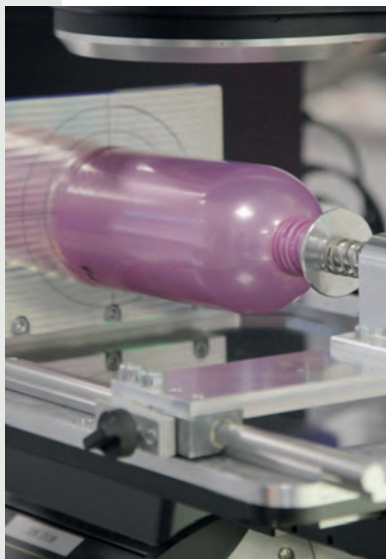

Digitale Flaschenvermessung



Überwachung Prozessparameter



UNTERNEHMENSKULTUR

CORPORATE CULTURE
CULTURE D'ENTREPRISE

Als Familienunternehmen leben wir eine wertebasierende Unternehmenskultur. Von größter Wichtigkeit ist uns dabei die:

As a family owned company we live a value-based management structure. Of very high importance for us are:

En tant qu'entreprise familiale, nos valeurs sont fondées sur la culture d'entreprise. De la plus haute importance sont pour nous:

✓ SICHERUNG VON ARBEITSPLÄTZEN UND STEIGERUNG DER ZUFRIEDENHEIT UNSERER MITARBEITER UND MITARBEITERINNEN

✓ SECURITY OF OUR WORKPLACES AND INCREASING OF THE SATISFACTION OF OUR PERSONNEL

✓ LA SÉCURITÉ DE L'EMPLOI ET LA SATISFACTION DE NOS EMPLOYÉS

✓ STÄNDIGE VERBESSERUNG UND OPTIMIERUNG DER FERTIGUNGSABLÄUFE

✓ CONSTANT IMPROVING AND OPTIMIZATION OF OUR PRODUCTION FLOW PROCESS

✓ L'AMÉLIORATION CONTINUE ET L'OPTIMISATION DES PROCESSUS DE FABRICATION

✓ RESSOURCENEFFIZIENZ DURCH ABFALLVERMEIDUNG UND KREISLAUFWIRTSCHAFT

✓ EFFICIENT USE OF RESOURCES DUE TO AVOIDANCE OF SCRAP AND CIRCULAR FLOW ECONOMY

✓ L'EFFICACITÉ DES RESSOURCES PAR LA PRÉVENTION ET LE RECYCLAGE DES DÉCHETS

✓ STÄNDIGE VERBESSERUNG DER ENERGIEEFFIZIENZ DURCH INVESTITION IN NEUESTE MASCHINEN- UND ANLAGENTECHNIK

✓ ONGOING IMPROVEMENT OF ENERGY EFFICIENCY DUE TO INVESTMENT IN STATE OF THE ART MACHINERY AND ENGINEERING

✓ L'AMÉLIORATION CONTINUE DE NOTRE EFFICACITÉ ÉNERGÉTIQUE AU TRAVERS D'INVESTISSEMENTS DANS DE NOUVELLES MACHINES ET INSTALLATIONS

✓ ENTWICKLUNG VON INNOVATIVEN PRODUKTEN DURCH EINEN HOHEN ANTEIL AN F&E LEISTUNGEN

✓ DEVELOPMENT OF INNOVATIVE PRODUCTS DUE TO A VERY HIGH LEVEL OF R&D

✓ LE DÉVELOPPEMENT DES PERFORMANCES DES PRODUITS ET SERVICES NOVATEURS DE NOTRE SERVICE RECHERCHE & DÉVELOPPEMENT

✓ OPTIMALE VERWENDUNG DES ERWIRTSCHAFTETEN KAPITALS DURCH DAUERHAFT REINVESTITIONEN

✓ OPTIMAL USE OF EARNED CAPITAL DUE TO PERMANENT REINVESTING

✓ L'UTILISATION OPTIMALE DU CAPITAL GÉNÉRÉ PAR LE RÉINVESTISSEMENT PERMANENT

✓ NULL GRANULATVERLUST

✓ ZERO LOSS OF GRANULES

✓ ZÉRO PERTE DE GRANULÉS

✓ EPRO FIT | DAS FITNESSCENTER FÜR UNSERE MITARBEITER UND MITARBEITERINNEN

✓ EPRO FIT | THE FITNESS CENTER FOR OUR EMPLOYEES

✓ EPRO FIT | LE CENTRE DE REMISE EN FORME POUR NOS EMPLOYÉS



GKV-VERHALTENSKODEX

GKV-CODE OF CONDUCT
CODE DE CONDUITE GKV



Die **EPROPLAST** GmbH ist nach dem GKV-Verhaltenskodex zertifiziert. Der GKV-Verhaltenskodex integriert sowohl Compliance-Vorgaben, als auch ethische und soziale Grundsätze. Hierzu gehören u.a. fundamentale Regeln gegen Korruption und kartellrechtswidrige Absprachen, aber auch internationale Vorgaben wie die UN-Menschenrechtscharta sowie anerkannte ethische Grundsätze.

The organization of the **EPROPLAST** GmbH is submitted to the GKV Code of Conduct and has been certified accordingly. The GKV Code of Conduct is integrating conduct requirements as well as ethical and social principals. This fundamentally rules against corruption and anti-trust consultations but also international rules such as the UN-human-rights-policy as well as other known ethic conventions.

L'organisation de la société **EPROPLAST** GmbH est soumise au code de conduite GKV et a été certifiée en conséquence. Le code de conduite GKV intègre des exigences de conduite ainsi que des principes éthiques et sociaux. Il s'agit fondamentalement de règles contre la corruption et les accords anti-concurrentiels mais aussi des règles internationales telles que la politique des droits de l'homme de l'ONU ainsi que d'autres conventions éthiques connues.

EINFÄRBUNG

COLORED PET-BOTTLES
BOUTEILLES PET AVEC COLORATION

Neben einer umfangreichen Palette an Standardfarben bieten wir auch individuelle Einfärbungen in transparent, transluzent und deckend an.

In addition to a wide range of standard colours, we also offer individual colours in transparent, translucent and opaque.

En plus d'une large gamme de couleurs standard, nous proposons également des colorations personnalisées en transparent, translucide et couvrant.



SCHUTZ VOR UV-(ULTRAVIOLETT) STRALUNG

PROTECTION AGAINST UV-RADIATION

BARRIÈRE CONTRE LES ULTRA-VIOLETS

Durch einen Zusatz von UV-Blockern wird das Eindringen von ultravioletter Strahlung verhindert.

By adding UV blockers the penetration of ultraviolet radiation will be prevented.

En ajoutant des bloqueurs d'UV, la pénétration du rayonnement ultraviolet sera empêchée.

Vergleich PET-Flasche mit/ohne UV-Blocker und Einfärbung amber transparent

comparison PET-bottle with/without UV-protection and color amber

Comparaison bouteille PET avec et sans bloqueur UV et de couleur ambre transparent

EPROPLAST PET-Flaschenmuster

Transmission in %

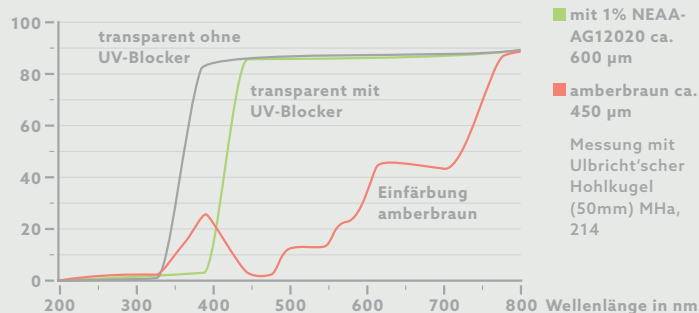

SCHUTZ VOR SAUERSTOFF (O₂)

PROTECTION AGAINST OXYGEN (O₂)

PROTECTION CONTRE L'OXYGÈNE (O₂)

TPO-EPROPLAST GR.

PET vs. 1,5% Valor

Total O₂ in ppb

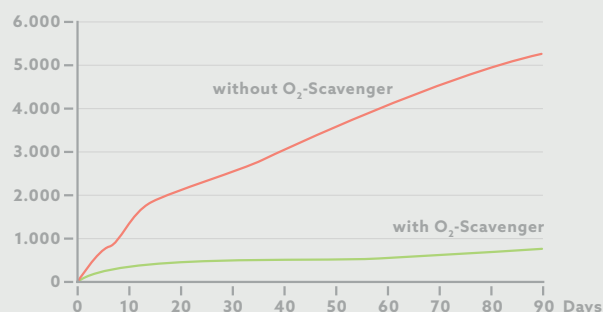

Sauerstoffabsorber: Vergleich PET Monolayer zu PET mit 1,5% Sauerstoffabsorber. Messung mit PET Flasche bb 330 ml, 21,5 g.

Oxygen scavenger: comparison PET-monolayer to PET with 1,5% oxygen scavenger. Measurement with PET bottle 330 ml, 21,5 g.

Absorbeur d'oxygène: Comparé au monocouche PET avec 1,5% absorbeur d'O₂. Mesure avec PET bouteille de 330 ml, 21,5 g.

Um den Sauerstoffeintrag zu verringern, kann dem Material (PET) ein sogenannter O₂-Scavenger beigelegt werden.

To reduce the penetration of oxygen we are able to add a so-called O₂-Scavenger.

Pour réduire la pénétration d'oxygène, un additif peut être ajouté au matériau PET un soi-disant capteur d'Oxygène (O₂)

NACHHALTIGKEIT - EINSATZ VON REGENERAT

SUSTAINABILITY - USE OF RECYCLATE

DURABILITÉ - UTILISATION DE MATIÈRES RÉGÉNÉRÉES



Durch das in Deutschland einmalige System der Pfandrückgabe von PET-Getränkeflaschen ist PET der Rohstoff mit der höchsten Recyclingquote. Fast 99% der Flaschen werden über die Pfandautomaten zurückgegeben und nach einer Aufbereitung wieder dem Flaschenfertigungsprozess zugeführt.

Die **EPROPLAST** GmbH kann heute auf Kundenwunsch nahezu alle produzierten Flaschen mit einem Anteil an Regenerat anbieten. Empfohlen wird aber ein Anteil von nicht mehr als 50%.

Due to the unique German deposit system for PET beverage bottles, PET is the raw material with the highest recycling rate within Germany. Almost 99% of the bottles are returned and fed back to the bottle production after the recycling process.

We are able to produce almost every bottle with an amount of recycling material. However we recommend an amount not exceeding 50%.

En Allemagne, grâce au système de consignes pour le remboursement des bouteilles plastiques, le PET est le matériau le plus recyclé. Près de 99% des bouteilles sont récupérées par ces automates de consigne et après un traitement, elles sont réutilisées dans le processus de fabrication des bouteilles.

Nous sommes en mesure de produire presque toutes les bouteilles avec une proportion de matières régénérées. Cependant, nous recommandons une quantité ne dépassant pas les 50%.

LET'S TALK ABOUT RPET - UNSERE FLASCHENSERIEN MIT PET-REZYKLAT

LET'S TALK ABOUT RPET - OUR BOTTLE SERIES WITH PET RECYCLATE

LET'S TALK ABOUT RPET - NOS GAMMES DE BOUTEILLES EN PET RECYCLÉ



PRODUKTBEISPIELE VON PET-FLASCHEN MIT REZYKLAT.

PET MILCHFLASCHEN

PET MILK-BOTTLES

PET BOUTEILLES DE LAIT

Milch ist gegenüber Licht sehr empfindlich. Speziell für Milchprodukte können Hochleistungs-Farbbatches mit sehr hoher Deckkraft eingesetzt werden.

Milk is very sensitive against light. Especially for milk products high performance master batches with a high level on opacity can be offered.

Les produits laitiers étant très sensible à la lumière, nous offrons une matière première avec une forte dose d'opacité.



Lichttransmission von PET-Flaschen

Wandstärke 0,3 mm

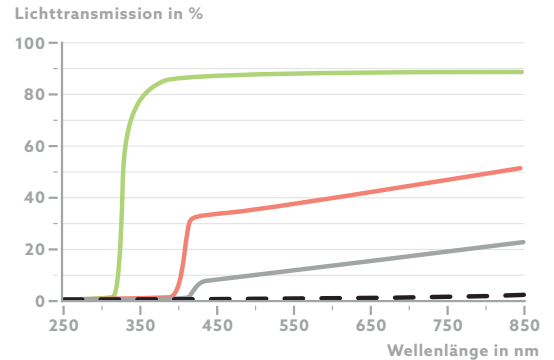

- transparente Flasche
- mit 2% Standard Farbbatch weiß
- mit 5% Spezialbatch
- mit 11% Spezialbatch T cc S704-C - UHT milk bottle

SERVICE - ETIKETTIEREN

SERVICE - READY LABELED PET-BOTTLES

SERVICE - BOUTEILLES PRÊTES PRÉ ÉTIQUETÉES

Wir können Rundflaschen mit Ihrem bereitgestellten Label etikettieren.

We can label round bottles with your provided label.

Nous pouvons étiqueter les bouteilles rondes avec votre étiquette fournie.



FLASCHEN MIT VERSCHLUSS

BOTTLES WITH CAP

BOUITEILLES AVEC BOUCHON



In Krankenhäusern und vielen öffentlichen Einrichtungen stehen heute bereits Wasserspenderautomaten. Den Patienten oder Besuchern wird eine leere PET-Flasche übergeben, die an diesen Automaten gefüllt werden kann.

Die in unserer FSSC22000-zertifizierten Produktion gefertigten Flaschen werden sofort nach dem Herstellungsprozess auf einer Verschließanlage mit einem Originalitätsverschluss versehen.

Bevor die Flasche an einem Automaten befüllt wird, muss der Verschluss mit integriertem Originalitätsband geöffnet werden. Daher gewährleisten diese Flaschen ein Höchstmaß an Hygiene.

In hospitals and many public facilities very often water dispensers are installed. The patients or visitors will get an empty bottle and these can be filled at the water station.

The bottles produced according to the FSSC22000-concept are immediately after the blowing process closed with a screw on cap with tamper evidence.

Before the bottles can be filled on the water station, the cap has to be opened. Therefore a maximum on hygiene is provided.

Les hôpitaux et de nombreux établissements publics sont aujourd'hui déjà équipés de distributeurs d'eau. On remet aux patients ou aux visiteurs une bouteille en PET vide qui peut être remplie à ces distributeurs.

Les bouteilles fabriquées dans notre production certifiée FSSC22000 sont immédiatement munies d'une fermeture inviolable après le processus de fabrication sur une ligne de bouchage.

Avant que la bouteille ne soit remplie sur un distributeur automatique, la fermeture avec bande d'invulnérabilité intégrée doit être ouverte. C'est pourquoi ces bouteilles garantissent un niveau d'hygiène maximal.



Entsprechend der neuen EU Verordnung ist ab Juli 2024 verpflichtend, dass alle Verschlüsse auf Einwegkunststoffgetränkerverpackungen fest mit der Flasche verbunden bleiben müssen. Aus diesem Grunde haben wir bereits verschiedenste Farben an Verschlüssen für Sie lagernd.

According to the EU legislative, plastic closures must remain attached to the beverage bottle during consumption by July 2024 at the latest. Therefore we offer these caps in various colors from stock.

Selon le nouveau règlement de l'UE, il est obligatoire à partir de juillet 2024 que toutes les fermetures des packs de boissons jetables restent fermement attachées à la bouteille. Pour cette raison, nous avons déjà en stock différentes couleurs de fermetures pour vous.

PET-FLASCHEN FÜR HPP-VERFAHREN

PET BOTTLES FOR HPP PROCESS

BOUEILLES PET POUR HPP PROCÉDURE

Die Hochdruckpasteurisierung ist eine Alternative zur thermischen Pasteurisierung von Lebensmitteln. Hierbei werden die gefüllten Flaschen mehrere Minuten einem gleichmäßigen Druck von 2.000 bis 7.000 bar ausgesetzt. Diese Behandlung inaktiviert die biologischen Funktionen von Mikroorganismen. Somit wird die Lebensdauer des Produktes verlängert, ohne die Qualität zu beeinträchtigen. Voraussetzungen für dieses Verfahren sind Kunststoffflaschen, da Verpackungen aus Glas dem enormen Druck nicht standhalten oder diesen nicht auf den Inhalt übertragen können. Für den Einsatz im HPP-Verfahren bieten wir gewichtsoptimierte PET-Flaschen an. Wir erfüllen auch individuelle Designwünsche. Je nach Design sind Volumina bis 1.000 ml verfügbar und können bei Bedarf mit einem Anteil recyceltem PET produziert werden.

High Pressure Pasteurization is an alternative to thermal pasteurization of food stuff. In this process filled bottles are exposed to a uniform pressure of 2.000-7.000 bars for several minutes. This method inactivates the biological functions of microorganisms. Thus, the product life is extended without impacting its quality. This method of preservation requires plastic bottles, as glass is unable to withstand the pressure and cannot transfer it to the contents of the bottle. Suitable for the HPP process we offer weight-optimized modifications of PET-bottles. We also fulfill individual design requests. Depending on the design, available volumes can range up to 1.000 ml and can be produced with a share of recycled PET if required.

Le traitement à haute pression est une alternative à la pasteurisation thermique d'aliments tels que les jus de fruits et légumes. Ici, les bouteilles remplies de jus fraîchement pressés sont exposées à une pression uniforme de 2.000 à 7.000 bars pendant plusieurs minutes. Cette méthode inactive les fonctions biologiques des microorganismes. Ainsi, la durée de vie du produit est prolongée sans nuire à sa qualité. De plus, cette méthode de conservation nécessite des bouteilles en plastique, car le verre ne peut pas résister à la pression et ne peut pas la transférer dans le contenu de la bouteille. Nous proposons des bouteilles à poids optimisé adaptées au procédé HPP. Selon la conception, les volumes disponibles peuvent aller jusqu'à 1.000 ml et peuvent être produites avec une proportion de PET recyclé si nécessaire.

1



- DIE PET-SAFTFLASCHEN WERDEN IN DER ANLAGE PLATZIERT.
- THE PET JUICE BOTTLES ARE PLACED IN THE SYSTEM.
- LES BOUTEILLES DE JUS EN PET SONT PLACÉES DANS LE SYSTÈME.

2



- ANSCHLIESSEND WIRD DIE DRUCKKAMMER MIT KALTEM, GEFILTERTEM WASSER GEFÜLLT.
- NEXT, THE PRESSURE CHAMBER IS FILLED WITH COLD, FILTERED WATER.
- ENSUITE, LA CHAMBRE DE PRESSION EST REMPLIE D'EAU FROIDE ET FILTRÉE.

3



- DER HYDROSTATISCHE DRUCK WIRD AUFGEBAUT (TYPISCHERWEISE 6.000 BAR) UND GEHALTEN. DURCH DAS WASSER KANN DIESER GLEICHMÄSSIG AUF DIE FLASCHEN UND DEREN INHALT WIRKEN.
- THE HYDROSTATIC PRESSURE IS BUILT UP (TYPICALLY TO 6.000 BARS) AND MAINTAINED. THROUGH THE WATER, THE PRESSURE EVENLY AFFECTS BOTH THE BOTTLES AND THEIR CONTENTS.
- LA PRESSION HYDROSTATIQUE EST ACCUMULÉE (GÉNÉRALEMENT JUSQU'À 6.000 BARS) ET MAINTENUE. A TRAVERS L'EAU, LA PRESSION AFFECTE UNIFORMÉMENT LES BOUTEILLES AINSI QUE LEUR CONTENU.

4



- DER DRUCK WIRD ABGEBAUT UND DAS WASSER ABGEPUMPT, SODASS DIE NUN HALTBAREN GETRÄNKE WIEDER ENTLADEN WERDEN KÖNNEN.
- THE PRESSURE IS REDUCED AND THE WATER PUMPED OUT, SO THAT THE NOW DURABLE DRINKS CAN BE UNLOADED.
- LA PRESSION EST RÉDUITE ET L'EAU POMPÉE, CE QUI PERMET DE DÉCHARGER LES BOISSONS MAINTENANT DURABLES.

A technical drawing on a teal grid background. It features a white line drawing of a bottle neck with a spring mechanism. The drawing is framed by a white rectangular border with dashed lines indicating dimensions. A dark teal horizontal bar with rounded ends is positioned across the middle of the drawing, containing the text.

INDIVIDUELLE KUNDENFORMEN

CUSTOMIZED BOTTLE DESIGN
FORMES DE CLIENTS INDIVIDUELLES

ANFRAGEFORMULAR

INQUIRY SHEET
QUESTIONNAIRE

Entwickeln Sie Ihre
eigene Flasche.

Design your own
bottle.

Créer votre propre
bouteille.

RUNDE FORM
ROUND SHAPE
FORME RONDE

Ø mm

OVALE FORM
OVAL SHAPE
FORME OVALE

B mm
T mm

FLASCHENHÖHE
BOTTLE HEIGHT
HAUTEUR BOUTEILLE

H mm
V ml

GEWINDE
THREAD
DIAMÈTRE COL

Ø mm

ZEICHNEN SIE IHRE FLASCHE.
DESIGN YOUR OWN BOTTLE.
ESSINEZ VOTRE BOUTEILLE.

KONTAKTDATEN
CONTACT DETAILS
DÉTAILS DU CONTACT

Name | name | Nom

E-Mail | e-mail

Telefon | phone | téléphone

ANWENDUNG
APPLICATION
APPLICATION

- Kosmetik | cosmetics | Cosmétique
- Reinigungsmittel & Chemie
detergents & chemistry
Nettoyants & Chimie
- Lebensmittel | food | Alimentaire
- Honig | honey | Miel
- Saucen | sauces | Sauces
- Speiseöl | edible oil | Huiles
- Essig | vinegar | Vinaigres
- Ketchup
- Spirituosen | liquors | Spiritueux
- Wein | wine | Vin
- Fruchtsaft | fruit juice | Jus de fruit
- Milch | milk | Lait
- Mixed drink | Cocktail
- Softdrink | Boissons non alcoolisées
- Bier | beer | Bière
- Coldfill | Remplissage à froid
- Hotfill | Remplissage à chaud

Bitte ausfüllen und per Mail an info@eproplast.com.
Please fill in the form sheet and send it back by mail to info@eproplast.com.
Veuillez remplir le formulaire et le renvoyer par mail à info@eproplast.com.



RUNDFLASCHEN

ROUND BOTTLES

BOUTEILLES RONDES

TALL BOSTON ROUND

		SLJM									
ml	30	50	60	100	100	150	200	250	300	500	
g	5,3	7	7	13	13	13 17	17 21	21	21	29,5	
	20/410	20/410	20/410	20/410	24/410 24/415	24/410	24/410 24/415	24/410 24/415	24/410	28/410	
mm	28	33	35	34,7	38	42	46,5	49	51	61,7	
mm	76,6	87,6	92	145,8	121,5 129	148	154 161	169,5 176	185,5	209,9	
	1; 2; 9	1; 2; 9	1; 2; 9	1; 2; 9	1; 2; 3; 6; 7; 8; 9	1; 2; 3; 6; 8; 9	1; 2; 3; 6; 7; 8; 9	1; 2; 3; 6; 7; 8; 9	1; 2; 3; 6; 8; 9	1; 2; 3; 5; 6; 8; 9; 10	



BOSTON ROUND EDGE

ml	150	200	250	300
g	13 17	21	21	21 24
	24/410	24/410	24/410	28/410
mm	49,5	54,1	60,9	61
mm	110,2	123	124	138,5
	1; 2; 3; 6; 8; 9	1; 2; 3; 6; 8; 9	1; 2; 3; 6; 8; 9	1; 2; 3; 5; 6; 8; 9; 10



BOSTON ROUND

* mit Warndreieck erhältlich
available with a warning triangle
disponible avec triangle d'avertissement

		CYLINDRICAL				MUNDSPÜLUNG			WIDE
	ml	100	250	300	500*	500	750	1.000	1.000
	g	9 11	21	21 24	29,5	33	36 39	36 39 42	39 42
		20/410	28/410	28/410	28/410 28-FM-DW 28/415	28 MS	28/410	28/410 28/415	28/410
	mm	41,8	60,9	67	70,9	70	75	78	89
	mm	106	125	123,5	188	197,7	218,8	265,5 274,2	208
		1; 2; 9	1; 2; 3; 5; 6; 8; 9; 10	1; 2; 3; 5; 6; 8; 9; 10	1; 2; 3; 5; 6; 7; 8; 9; 10	14	1; 2; 3; 5; 6; 8; 9; 10	1; 2; 3; 5; 6; 8; 9; 10	1; 2; 3; 5; 6; 8; 9; 10



EPROSHARP

	ml	50	100	150	200	500
	g	13	13 17	17	21	29,5
		24/415	24/410	24/410	24/410	28/410
	mm	37,5	38	43	48,1	64
	mm	79,5	118,1	137	146,9	189,8
		1; 2; 3; 7; 9	1; 2; 3; 6; 8; 9	1; 2; 3; 6; 8; 9	1; 2; 3; 6; 8; 9	1; 2; 3; 5; 6; 8; 9; 10



EPROTUBE

	ml	200	250	500
	g	21	21	30
		24/410	24/410 24/415	24/410
	mm	48,1	48	67,4
	mm	142	173,1 182,5	173,1
		1; 2; 3; 6; 8; 9	1; 2; 3; 6; 7; 8; 9	1; 2; 3; 6; 8; 9



EPROVERA

	ml	150	200	250	300	500	1.000
	g	15 17,5 21	15	21 24	24 29,5	29,5 36	39 42
		ROPP 28	ROPP 28	28/410 ROPP 28	28/410 ROPP 28	28/410 ROPP 28	28/410 ROPP 28
	mm	49,5	54,8	60	65	77,5	87,8
	mm	115	125	128,3 130,3	136,9 138,9	155,3 157,3	216,5 218,5
		1	1	1; 2; 3; 5; 6; 8; 9; 10	1; 2; 3; 5; 6; 8; 9; 10	1; 2; 3; 5; 6; 8; 9; 10	1; 2; 3; 5; 6; 8; 9; 10



EPROCARE

	ml	200	300	400
	g	21 24	24	29,5
		28/410	28/410	28/410
	mm	59	59	59
	mm	109	146	191,8
		1; 2; 3; 5; 6; 8; 9; 10	1; 2; 3; 5; 6; 8; 9; 10	1; 2; 3; 5; 6; 8; 9; 10



OPTIMAX

OPTIMAX II				
	ml	200	250	250
	g	21	21	21
		24/415	28/415	24/415
	mm	50	50	53
	mm	142	145	154,5
		1; 2; 3; 7; 9	7	1; 2; 3; 7; 9



CATCH

	ml	500
	g	29,5
		28/410
	mm	71,5
	mm	167,3
		1; 2; 3; 5; 6; 8; 9; 10



EPROPHARM

EPROPHARM II

	ml	10	15	20	30	50	100	150	200
	g	7,8	7,8	7,8	7,8	9	15	15	21
		GL18/ DIN18	GL18/ DIN18	GL18/ DIN18	GL18/ DIN18	GL18/ DIN18	ROPP 28	ROPP 28	ROPP 28
	mm	22,4	25	28,6	32	37	46	50	50,9
	mm	60	60	60	68	77	95	112	138
		9	9	9	9	9	1	1	1









EPROALPHA

	ml	125	200
	g	15	24
		ROPP 28	ROPP 28
	mm	48,5	56,4
	mm	108	125
		1	1









TUBO ROUND

 ml	25
 g	6,7 7 7,8
	ROPP 18 20/410 GL18/DIN18
 mm	20,8
 mm	108,4 110,5 111,8
	1; 2; 9









EPROBALL

 ml	500
 g	29,5
	28/410
 mm	100,3
 mm	123
	1; 2; 3; 5; 6; 8; 9; 10



ROUND FIRE

 ml	1.000
 g	29,5
	28/410
 mm	85,4
 mm	237,5
	1; 2; 3; 5; 6; 8; 9; 10

Zertifiziert von TÜV Halle gem. DIN EN ISO 8317: 2004-11 kindergesicherte Verpackung.

Certified from TÜV Halle according to DIN EN ISO 8317: 2004-11 child-safe packaging.

Certifié par TÜV Halle selon la norme DIN EN ISO 8317 : 2004-11 sécurité enfants emballage.



TECHNO ROUND

	ml	125	250	1.000
	g	13	21	36 39,5 42
		24/410	24/410	28/410
	mm	46,4	57	80
	mm	108,9	138,4	264,5
		1; 2; 3; 6; 8; 9	1; 2; 3; 6; 8; 9	1; 2; 3; 5; 6; 8; 9; 10



EPROFUEL

	ml	200
	g	21
		24/410
	mm	52
	mm	192,9
		1; 2; 3; 6; 8; 9



E-LISMOKE TALL & XL

* Zertifiziert von Laboratoire LNE gemäß EN ISO 8317 (kindergesicherte Verpackung)

Certified from Laboratoire LNE according to EN ISO 8317 (child-safe packaging)

Certifié par Laboratoire LNE selon EN ISO 8317 (Sécurité enfants emballages)

		TALL		XL	XL
	ml	10*	10*	30	60
	g	2,3	2,3	10	10
		esmo CAP	esmo CAP	20/410 esmo CAP	20/410 esmo CAP
	mm	19,5	20,75	30,6	30,6
	mm	53,5	50	67,35	111,35
		6	6	6	6



EPROFOAM

EPROFOAM II

ml	150	150	200
g	21 23,5	21 23,5	23,5
	43-400	43-400	43-400
mm	48	48	48
mm	136,6	132	158
	-	-	-



EPROGEWÜRZ

ml	100
g	11
	38-400
mm	42,4
mm	101
	12



PET PACKER

ml	75	175
g	11 13	21
	38-400	38-400
mm	46,4	56,5
mm	81	97,2
	12	12



EPROJAR

 ml	500
 g	30
	53SP400
 mm	76
 mm	150,5
	-



The image features two clear glass oval bottles against a teal background. The bottle on the left is taller and wider, while the one on the right is shorter and narrower. Both bottles have a similar design with a slightly tapered neck and a rounded body. A semi-transparent teal circle is overlaid on the left side of the image, containing the text.

OVALFLASCHEN

OVAL BOTTLES

BOUTEILLES OVALES

BASIC OVAL

BASIC OVAL II

	ml	50	75	100	150	250
	g	7	9	11 13	13 15	21
		20/410	20/410	20/410	20/415	24/410 24/415
	mm	40	43,5	46	57,4	70
	mm	25,3	27,5	30	36,5	35,5
	mm	91,4	106	117	136,4	164,4 173
		1; 2; 9	1; 2; 9	1; 2; 9	-	1; 2; 3; 6; 7; 8; 9



EPROCARE OVAL

	ml	250	300	400
	g	21	24	29,5
		28/410	28/410	28/410
	mm	58,1	58,1	74
	mm	49,1	49,1	58,2
	mm	152,8	176,2	160
		1; 2; 3; 5; 6; 8; 9; 10	1; 2; 3; 5; 6; 8; 9; 10	1; 2; 3; 5; 6; 8; 9; 10

Gewindeausrichtung möglich
Neck orientation possible
Possibilité d'orientation du cou









DOMO

	ml	500
	g	24
		28/410
	mm	78,5
	mm	60,5
	mm	165,5
		1; 2; 3; 5; 6; 8; 9; 10







EPOVAL

 ml	500
 g	29,5
	28/410
 mm	97,5
 mm	58,5
 mm	163,9
	1; 2; 3; 5; 6; 8; 9; 10





SHORT OVAL

 ml	500
 g	24
	28/410
 mm	91
 mm	60
 mm	156,5
	1; 2; 3; 5; 6; 8; 9; 10



EPOCLEAN

 ml	500
 g	21 24
	28/410
 mm	90,7
 mm	52,5
 mm	196,2
	1; 2; 3; 5; 6; 8; 9; 10



OPTIVAL

OPTIVAL II

ml	150	150	250
g	17 21	17 21	21
	24/410	24/410	24/415
mm	67	67	74
mm	34,7	34,7	38
mm	131,7	131,7	162,4
	1; 2; 3; 6; 8; 9	1; 2; 3; 6; 8; 9	1; 2; 3; 7; 9



E-MAGIC

ml	200	250	300
g	21	21	21
	28/410	28/410	28/410
mm	57	60,5	64
mm	37	40,5	43
mm	161,3	170	178,3
	1; 2; 3; 5; 6; 8; 9; 10	1; 2; 3; 5; 6; 8; 9; 10	1; 2; 3; 5; 6; 8; 9; 10



CONE

ml	250
g	21
	24/410
mm	75
mm	42,5
mm	169,4
	1; 2; 3; 6; 8; 9



APOTHEKERFLASCHE

	ml	500
	g	29,5
		28/415 28/B408
	mm	80
	mm	47,5
	mm	210,5 216,5
		7



EPROMOWA

	ml	500
	g	33
		28 mm MS
	mm	87
	mm	46,5
	mm	220,75
		14



FAMILY

	ml	750	1.000
	g	36	39 42
		28/410	28/410
	mm	95	97,5
	mm	54	65
	mm	255	260
		1; 2; 3; 5; 6; 8; 9; 10	1; 2; 3; 5; 6; 8; 9; 10



SQUEEZI-A

	g	350
	g	21
		25 mm snap on
	mm	73
	mm	40,6
	mm	147,7
		11.2



SQUEEZI-SLIM

	ml	250
	g	21
		25 mm snap on
	mm	67
	mm	42,4
	mm	142,5
		11.1









SQUEEZI-KOS

	ml	200	250	300
	g	17	21	25
		25 mm snap on	25 mm snap on	25 mm snap on
	mm	67	72	72,5
	mm	39,6	40,6	39,6
	mm	129,7	147,5	173
		11.1	11.1	11.1









POCKET SQUEEZE

 ml	66
 g	8,5
	18 mm snap on
 mm	46
 mm	27,8
 mm	90
	-



MINI SQUEEZE

 ml	66
 g	8
	18 mm snap on
 mm	49
 mm	27,8
 mm	90,5
	-







RECHTECKFLASCHEN
RECTANGULAR BOTTLES
BOUTEILLES RECTANGULAIRES

EPROSQUARE

	ml	100	200	300
	g	13	21	21
		24/410	24/410	24/410
	mm	39,6	49	52,3
	mm	39,6	49	52,3
	mm	94,3	127,8	150,1
		1; 2; 3; 6; 8; 9	1; 2; 3; 6; 8; 9	1; 2; 3; 6; 8; 9

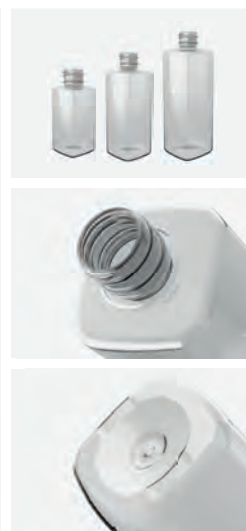

EPROSQUARE FLAT

	ml	300
	g	21
		24/410
	mm	72,5
	mm	49
	mm	127,8
		1; 2; 3; 6; 8; 9





EPROSWING

	ml	100	200	300
	g	13	21	21
		24/410	24/410	24/410
	mm	47,8	55,5	58
	mm	37,1	45	51,6
	mm	93,5	124,2	148,4
		1; 2; 3; 6; 8; 9	1; 2; 3; 6; 8; 9	1; 2; 3; 6; 8; 9









EPROFOAM SQUARE

 ml	300
 g	23 26
	40-400
 mm	55
 mm	55
 mm	157,1
	-



EPROKANISTER

 ml	5.000
 g	120
	SK50
 mm	187,5
 mm	130
 mm	319,5
	-







SPRÜHFLASCHEN
TRIGGER SPRAY BOTTLES
VAPORISATEURS

SPEZIALGEWINDE TRIGGERFIX® SPECIAL THREAD | FILETAGE SPÉCIAL

Fixiert die Verschlusskappe trotz Rückdrehung der Sprühpistole.

Is fixing the cap in spite of counter clockwise turning of the trigger.

Fixe le bouchon en dépit de la rotation inverse du pistolet.



KEULENFLASCHE

	ml	500	750	1.000
	g	29,5	36 39	39 42
		28/410	28/410	28/410
	mm	82,5	83,5	93,5
	mm	169	217	241,3
		1; 2; 3; 5; 6; 8; 9; 10	1; 2; 3; 5; 6; 8; 9; 10	1; 2; 3; 5; 6; 8; 9; 10



WEIMAR

	ml	500*	750	1.000
	g	29,5 36	36	39,5 42
		28/410	28/410	28/410
	mm	106	108,5	113
	mm	56	60	66
	mm	191,5	228	262
		1; 2; 3; 5; 6; 8; 9; 10	1; 2; 3; 5; 6; 8; 9; 10	1; 2; 3; 5; 6; 8; 9; 10

* mit Warndreieck erhältlich
available with a warning triangle
disponible avec triangle d'avertissement



OCEAN

	ml	500	750	1.000
	g	29,5	36	39,5 42
		28/410	28/410	28/410
	mm	97,6	103,4	110,7
	mm	49,1	60,7	68,5
	mm	225,6	248,8	268,5
		1; 2; 3; 5; 6; 8; 9; 10	1; 2; 3; 5; 6; 8; 9; 10	1; 2; 3; 5; 6; 8; 9; 10



POTSDAM

	ml	750	1.000
	g	36 39	39
		28/410	28/410
	mm	95	99
	mm	60,4	69
	mm	255,5	260,5
		1; 2; 3; 5; 6; 8; 9; 10	1; 2; 3; 5; 6; 8; 9; 10



JENA

	ml	500
	g	29,5
		28/410
	mm	98,7
	mm	51,5
	mm	221
		1; 2; 3; 5; 6; 8; 9; 10



ROSTOCK

	ml	500
	g	29,5
		28/410
	mm	89,9
	mm	50
	mm	232
		1; 2; 3; 5; 6; 8; 9; 10

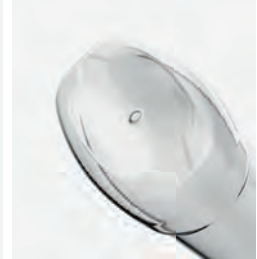

STRALSUND

	ml	500
	g	29,5
		28/410
	mm	90
	mm	50
	mm	231,3
		1; 2; 3; 5; 6; 8; 9; 10

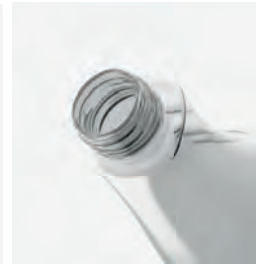







BOSTON ROUND

* mit Warndreieck erhältlich
available with a warning triangle
disponible avec triangle d'avertissement

	ml	500*	750	1.000
	g	29,5	36 39	36 39 42
		28/410	28/410	28/410
	mm	70,9	75	78
	mm	188	218,8	265,5 274,2
		1	1; 2; 3; 5; 6; 8; 9; 10	1; 2; 3; 5; 6; 7; 8; 9; 10







EPROVERA

 ml	500	1.000
 g	29,5 36	39 42
	28/410	28/410
 mm	77,5	87,8
 mm	155,3 157,3	216,5 218,5
	1; 2; 3; 5; 6; 8; 9; 10	1; 2; 3; 5; 6; 8; 9; 10



DESSAU

 ml	500	750
 g	29,5	36
	28/410	28/410
 mm	90,5	98,1
 mm	45,6	59,5
 mm	241,5	245
	1; 2; 3; 5; 6; 8; 9; 10	1; 2; 3; 5; 6; 8; 9; 10







FLASCHEN FÜR KALTABFÜLLUNG

BOTTLES FOR COLD FILL

BOUTEILLES POUR REEMPLISSAGE À FROID

EPROJUICE

	ml	150	250	330	500	750	1.000
	g	16	16	18	24 27	27	32
		38 mm 2-start/ 3-start	38 mm 2-start/ 3-start	38 mm 2-start/ 3-start	38 mm 2-start/ 3-start	38 mm 2-start/ 3-start	38 mm 2-start/ 3-start
	mm	49	55	60	67 67,5	75,5	84
	mm	112,5 130,5	148 149	165,5 163,7	197,8 198 199	229 231,1	256
		13	13	13	13	13	13



EPROJUICE SQUARE

	ml	150	250	330	500	1.000
	g	16	18	18	27	32
		38 mm 2-start/ 3-start	38 mm 2-start/ 3-start	38 mm 2-start/ 3-start	38 mm 2-start/ 3-start	38 mm 2-start/ 3-start
	mm	46,5	53	56	64	77,5
	mm	46,5	53	56	64	77,5
	mm	111	143,5	162,5	190	254,5
		13	13	13	13	13



EPROJUICE-R

ml	250	500	1.000
g	16	24	32
	38 mm 2-start	38 mm 2-start	38 mm 2-start
mm	55	67,5	84
mm	149	199,5	256
	13	13	13



Flaschen mit CE-Kennzeichnung für Ausschankmaß gemäß Konformitätserklärung nach europäischer Richtlinie 2014/32/EU

Bottles with CE-marking for serving size according to the declaration of conformity according to European Directive 2014/32/EU

Bouteilles avec marquage CE pour la mesure de la capacité à servir conformément à la déclaration européenne de conformité directive 2014/32/UE



EPROJUICE WAVE

ml	250
g	16
	38 mm 2-start
mm	55
mm	149
	13



EPROROUND

	ml	100	150	200	250	500
	g	16	16	19	18 19	27 32
		38 mm 2-start	38 mm 2-start	38SP400	38 mm 3-start 38 mm 2-start 38-400	38 mm 2-start 38-400
	mm	42	48	50	50	64
	mm	93,5	11	129	158 151,1	187,5 183
		13	13	12	12; 13	12; 13



EPROSLIM

	ml	250
	g	18 24
		38 mm 2-start
	mm	55
	mm	165
		13



SQUEEZI-HONIG

	g	250	350	500
	g	17	21	25
		25 mm snap on	25 mm snap on	25 mm snap on
	mm	67	72	80
	mm	40,5	40,6	42
	mm	118,5	147,5	173,2
		11.1	11.1;	11.1



- * Füllmenge in g Honig mit einem spezifischen Gewicht von 1,4 g/cm³
- * Content in g honey with a specific weight of 1.4 g/cm³
- * Volume en g de miel avec un poids spécifique de 1,4 g/cm³

✓ **SKALA BEIDSEITIG:**
AUS BEIDEN RICHTUNGEN ABLESBAR

✓ **SCALE ON BOTH SIDES:**
READABLE IN TWO POSITIONS

✓ **GRADUATION DES DEUX CÔTÉS:** LISIBLE DANS LES DEUX SENS

✓ **MEMBRANVENTIL:**
EXAKTE UND SAUBERE DOSIERUNG

✓ **MEMBRANE VALVE:**
PRECISELY, CLEAN DOSAGE

✓ **MEMBRANE VALVE:**
DOSAGE EXACT ET PROPRE

SQUEEZI-BEE

	g	250	350	500
Randvollvolumen in	ml	190	264	367
	g	17	21	25
		25 mm snap on	25 mm snap on	25 mm snap on
	mm	68,8	70	75,8
	mm	40,75	42,05	44,09
	mm	124,1	144	170
		11.2	11.2	11.2

Verschluss mit Originalitätssicherung
with tamper evidence and membran valve
Fermeture à sécurité inviolable



HONIGWABEN

	g	250	350	500
	g	21	21	26
		29 mm snap on	29 mm snap on	29 mm snap on
	mm	80,3	85,2	99
	mm	32,1	40,2	44
	mm	114,2	133,1	154,8
		-	-	-



HONIG-SLIM

	ml	250
	g	21
		25 mm snap on
	mm	67
	mm	42,4
	mm	142,5
		11.1









SQUEEZI-A

	g	350
	g	21
		25 mm snap on
	mm	73
	mm	40,6
	mm	147,7
		11.2

Verschluss mit Originalitätssicherung
with tamper evidence and membran valve
Fermeture à sécurité inviolable









SQUEEZI-WAVE

 g	500
 g	25
 mm	25 mm snap on
 mm	82
 mm	44,9
 mm	173,5
 mm	11.1









HONEY OVAL

 g	350
 g	21
 mm	38-400
 mm	72,3
 mm	45,2
 mm	145
 mm	12



SQUEEZER OVAL

 ml	250
 g	21
 mm	38SP400
 mm	75,3
 mm	47,7
 mm	124
 mm	12



EPROWEIN

	ml	200	750
	g	22	47,5 48
		ROPP 28	BVS30H PCO 28 mm
	mm	56	75,6
	mm	138	267 266
		1	-



TASCHENFLASCHE

	ROUND					
	ml	20	20	30	95	100
	g	6,7	6,7	6,7	15 17,5	15
		ROPP 18	ROPP 18	ROPP 18	ROPP 28	ROPP 28
	mm	24,8	-	-	-	-
	mm	-	32	36	57,8	57,8
	mm	-	20	23	28,8	28,8
	mm	76,2	67,2	75,3	108,2	111
		1	1	1	1	1



DELI 300

	ml	300
	g	21
		38SP400
	mm	71,8
	mm	57,2
	mm	140,5
		12





FLASCHEN FÜR DIE HEISSABFÜLLUNG
BOTTLES FOR HOT-FILLING
BOUTEILLES POUR REEMPLISSAGE À CHAUD

PET HOTFILL

PET BOTTLES FOR HPP

BOUITEILLES PET POUR HPP

Die Heißabfüllung ist eine sichere und seit vielen Jahren bekannte Abfülltechnologie. Durch die Heißabfüllung können z.B. Fruchtsäfte mikrobiologisch sicher abgefüllt werden. Vorhandene Anlagen zur Abfüllung von Glasflaschen können mit nur geringen Investitionen auf die Abfüllung von PET-Flaschen umgerüstet werden. Bei weniger als 50 Mio. Füllungen pro Jahr ist die Heißabfüllung von PET-Flaschen eine sehr wirtschaftliche Alternative zur kaltseptischen Abfüllung.

Hot filling is a very safe method of filling technology and has been known for many years. With hot filling for example fruit juices can be microbologically filled safe. Existing equipment for filling glass bottles can be used with only low investment for the adaption of PET bottles. With less than 50 million fillings per year the hot filling technology of PET bottles is a very economical alternative in comparison to cold aseptic filling.

La technique de remplissage à chaud est depuis des années une technique sûre et connue. Grâce au remplissage à chaud, les jus de fruits par exemple sont remplis dans un environnement microbologique sûr. Les installations existantes de remplissage de bouteilles en verre peuvent être modifiées avec peu d'investissement pour passer aux bouteilles PET. Avec moins de 50 millions d'unités par an, le remplissage à chaud de bouteilles PET est une alternative très économique comparé aux lignes aseptiques à froid.

PREFORM



Preform = Amorphe Struktur
preforms = amorphous structure
Preform = structure amorphe

COLDFILL

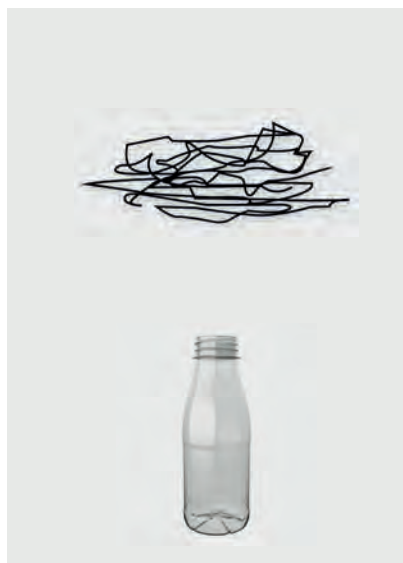

streckgeblasene Flasche Coldfill =
spannungsinduzierte Kristallinität
stretch blow moulding of coldfill bottles =
stress induced crystallinity
Moulage par soufflage avec étirage
Coldfill = Cristallinité déterminée

HOTFILL

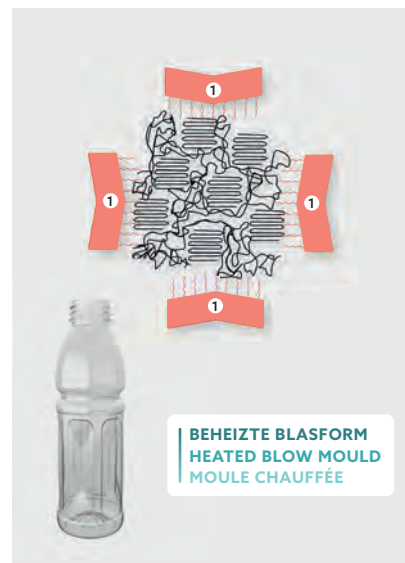

PET Hotfillflasche = thermische
Kristallinität
PET hotfill bottles = thermal
crystallinity
PET bouteille Hotfill = Cristallinité
thermique

Im PET Hotfill-Blasprozess wird der Kunststoff in der Blasform auf Temperaturen von bis zu 150°C aufgeheizt. Dadurch erfolgt eine Kristallitbildung in der Molekülstruktur. Durch diese Kristallisation ist es möglich, heiße Flüssigkeiten, ohne dass die Flasche unkontrolliert schrumpft, zu füllen.

With the heat set blowing process the resin is blown in heated blow moulds with temperatures of up to 150°C. Due to this process thermal crystallites will form inside the molecules structure. Therefore it is possible to fill such bottles with hot liquids avoiding uncontrolled shrinkage.

Dans le processus de moulage par soufflage avec étirage Hot Fill (Remplissage à chaud), le PET est chauffé dans un moule à une température pouvant atteindre 150°C. Ainsi, se forme une cristallite de la structure moléculaire. Grâce à cette cristallisation, il est possible de remplir des liquides chauds sans que la bouteille rétrécit de manière incontrôlée.

DER PET HOTFILL-BLASPROZESS

THE PET HOTFILL BLOWING PROCESS

LE PET HOT FILL PROCESSUS DE SOUFFLAGE

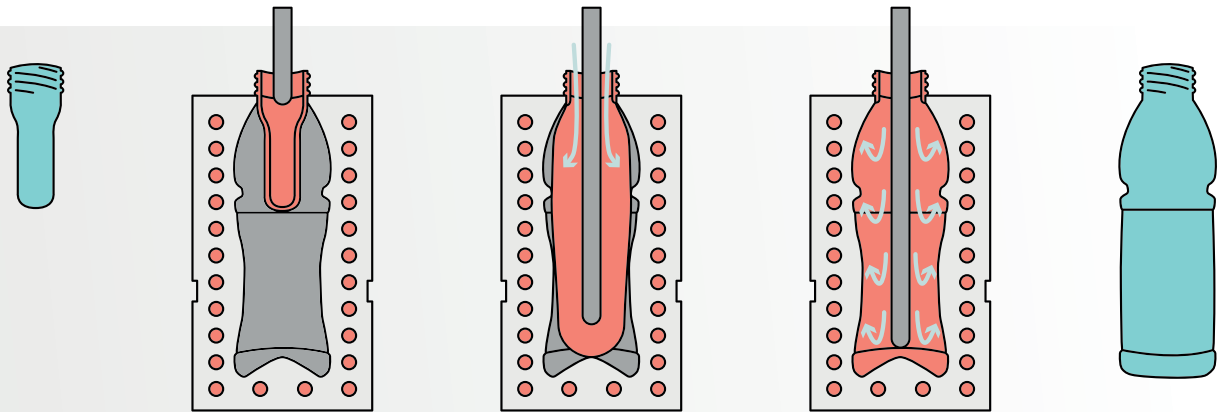

HEIZEN
HEATING
CHAUFFER

STRECKEN
STRETCHING
ETIRER

BLASEN
BLOWING
SOUFFLER

HEIZEN
HEATING
CHAUFFER

KÜHLEN
COOLING
REFROIDIR

PET-STANDARD-HOTFILL

STANDARD PET HOTFILL

STANDARD BOUTEILLE HOT FILL

Konventionelle PET-Hotfill-Flaschen sind zur Kompensation der Volumenkontraktion des Füllgutes nach der Abkühlung mit sog. Panel- oder Ringstrukturen ausgelegt.

In order to compensate the volume shrinkage after cooling down, conventional PET hot fill bottles are designed with what is called panel- or ring structure. Disadvantage:

Pour compenser la perte de volume après refroidissement, les bouteilles classiques sont dessinées avec des parois faibles et des parois fortes.

EIGENSCHAFTEN DIESER TECHNIK SIND:

- ⊖ MEIST GESLEEVT
- ⊖ HÖHERES FLASCHENGEWICHT

CHARACTERISTICS OF THIS TECHNOLOGY ARE:

- ⊖ MOSTLY SLEEVED
- ⊖ HIGHER BOTTLE WEIGHT

CARACTÉRISTIQUES DE CETTE TECHNIQUE SONT:

- ⊖ LE PLUS SOUVENT EN SLEEVE
- ⊖ POIDS PLUS ÉLEVÉ DE LA BOUTEILLE

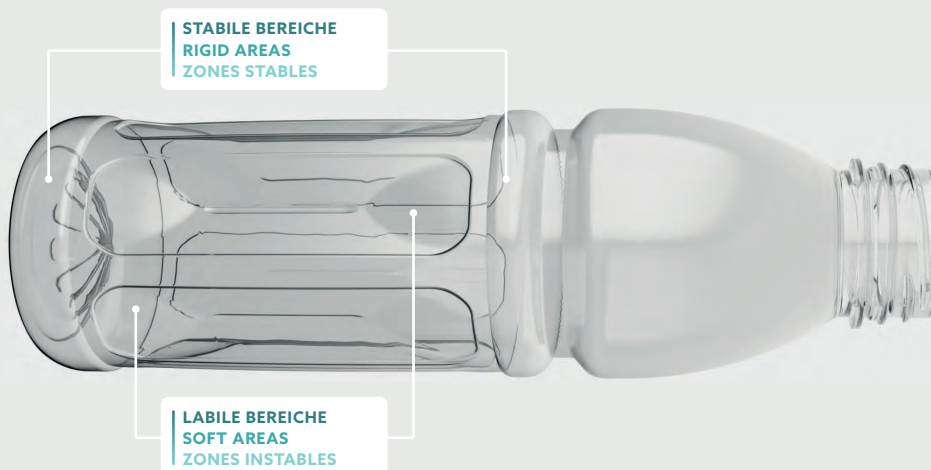

PANELLESS PET-HOTFILL TECHNIK (N2) DAS PRINZIP
THE PANELLESS PET HOTFILL TECHNOLOGY (N2) THE APPROACH
LES BOUTEILLES SANS PANNEAUX PET HOT-FILL TECHNIQUE LE PRINCIPE

Abfülltechnik von PET-Flaschen mit glatter Außenfläche.
 Filling technology of PET hotfill bottles with flat outside surface.
 Technique de remplissage de bouteilles HOT FILL avec surface externe lisse.

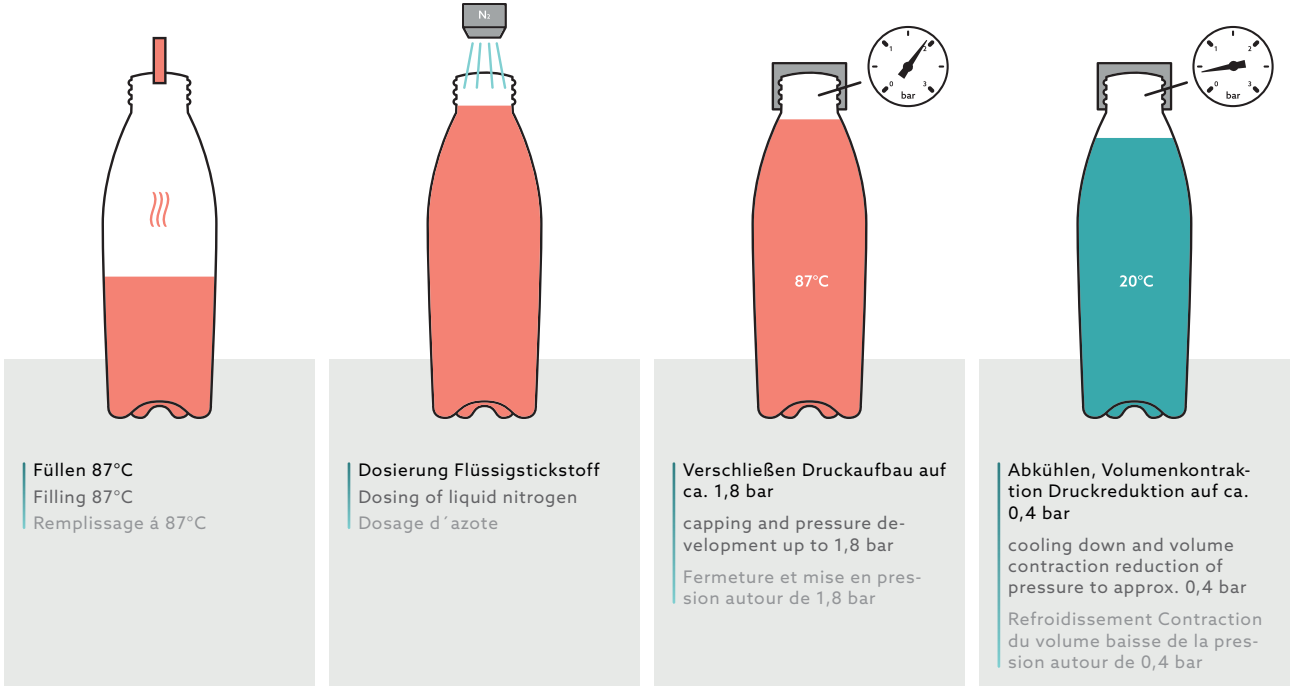

VORTEILE DER PANELLESS PET-HOTFILL TECHNIK
THE ADVANTAGE OF PANELLESS PET HOTFILL TECHNOLOGY
LES AVANTAGES DE LA BOUTEILLE SANS PANNEAUX PET HOT-FILL TECHNIQUE

VORTEILE:

- + GLATTE AUSSENFLÄCHE
- + EINFACHES ETIKETTIEREN
- + GERINGES FLASCHENGEWICHT
- + GROSSE DESIGNFREIHEIT
- + OPTIK WIE BEI EINER KALTASEPTISCH GEFÜLLTEN FLASCHE

ADVANTAGE:

- + THE FLAT OUTSIDE SURFACE
- + SIMPLE TO LABEL
- + LOW BOTTLE WEIGHT
- + LARGE FREEDOM OF DESIGN
- + DESIGN LIKE COLD ASEPTIC FILLED BOTTLES

AVANTAGES:

- + SURFACE EXTÉRIEURE LISSE
- + ÉTIQUETAGE FACILE
- + POIDS LÉGER DE LA BOUTEILLE
- + GRANDE LIBERTÉ DE DESIGN
- + OPTIQUE ÉQUIVALENT À UNE BOUTEILLE REMPLIE À FROID SUR UNE CHÂÎNÉ ASEPTIQUE



WEITERE ANWENDUNGEN FÜR PET-HOTFILL

MORE APPLICATIONS FOR PET HOTFILL

AUTRES APPLICATIONS POUR LE PET HOT FILL



Um Produkte mikrobiologisch einwandfrei abzufüllen, ist der PET Heißfüllprozess für viele Bereiche verwendbar wie z.B.:

- ✓ *SOSSEN*
- ✓ *SUPPEN*
- ✓ *KETCHUP*
- ✓ *KONFITÜREN*
- ✓ *UVM.*

To achieve microbiology correct filling of products the PET hotfill process is used in various fields, e.g.:

- ✓ *SAUCES*
- ✓ *SOUPS*
- ✓ *KETCHUP*
- ✓ *JAM*
- ✓ *AND MANY MORE*

Pour conditionner des produits de manière microbiologiquement irréprochable, le processus de remplissage à chaud du PET peut être utilisé dans de nombreux domaines tels que:

- ✓ *SAUCES*
- ✓ *SOUPES*
- ✓ *KETCHUP*
- ✓ *CONFITURES*
- ✓ *ET BIEN PLUS ENCORE*

EPROJUICE HF

PANELLESS

	ml	330	500	750	1.000
	g	22,6	29,5	42,5	42,5
		38 mm 2-gang HF	38 mm 2-gang HF	38 mm 2-gang HF	38 mm 2-gang HF
	mm	60	67	76	84
	mm	172,8	208,6	243	270
		13	13	13	13



TRANSWAVE HF

PANELLESS

	ml	1.000
	g	42,5
		38 mm 2-gang HF
	mm	85
	mm	269,6
		13









E-SMOOTH HF

PANELLESS

	ml	250
	g	22,6
		38 mm 2-gang HF
	mm	55
	mm	159
		13







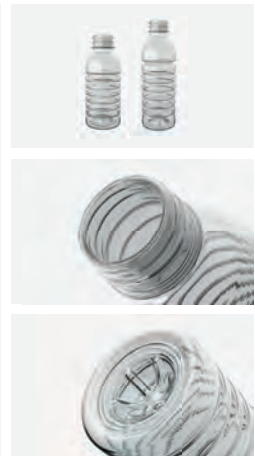

EPRORINGFLASCHE HF

 ml	330	500
 g	30	35
	38 mm 2-gang HF	38 mm 2-gang HF
 mm	62,5	67
 mm	158,2	204
	13	13



PANEL-A HF

 ml	500
 g	42,5
	38 mm 2-gang HF
 mm	65,5
 mm	220,8
	13



DELI HF

 ml	250	500
 g	21	32
	38-400	38-400
 mm	76,4	91,5
 mm	46,2	55
 mm	127,5	176
	12	12

PET-Flasche für die Heißabfüllung von Ketchup, Saucen & Sirup. Verschluß mit Membranventil.

PET-bottle for hot filling of ketchup, sauces & sirup. Closure with membrane valve.

Bouteille PET pour remplissage à chaud de ketchup, sauces et sirops. Fermeture avec soupape à membrane.



SQUEEZER OVAL HF

	ml	250
	g	19 21
		38SP400
	mm	74,4
	mm	47,8
	mm	126,5
		12



MAPLE CLAD SLIM HF

	ml	370	370
	g	32	32
		38-400	28 TE
	mm	94	94
	mm	46,5	46,5
	mm	173,1 176,1	173,1 176,1
		12	-









MAPLE CLAD WIDE HF

	ml	250	370
	g	21	32
		38-400	38-400
	mm	76	88
	mm	45	47,5
	mm	104,3	166,6
		12	12



MAPLE RIBS HF

 ml	190
 g	23
	33-400
 mm	83
 mm	38
 mm	131,4
	-

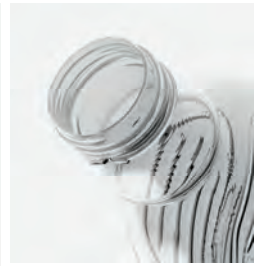



VERSCHLÜSSE

CLOSURES
BOUCHONS



SCHRAUBVERSCHLUSS SCREW CLOSURE | BOUCHON À VIS

	20/410	24/410	24/415
--	---------------	---------------	---------------

1 CO/PL CO/PL CO/PL

	28/410	28 FM-DW	28-B408
--	---------------	-----------------	----------------

1 CO/PL CO/PL CO/PL

	ROPP 18	ROPP 28
--	----------------	----------------

1 CO/LI/PL CO/LI/PL



KLAPPDECKEL HINGED FLIP TOP | COUVERCLE SUPÉRIEUR RABATTABLE

	20/410	24/410	24/415	28/410
--	---------------	---------------	---------------	---------------

2 CO CO CO CO



KIPPDECKEL DISC TOP | COUVERCLE BASCULANT

	24/410	24/415	28/410
--	---------------	---------------	---------------

3 CO CO CO



**DICHTUNG
SEAL
JOINT**

CO: KONUSDICHTUNG | CONE | CÔNE D'ÉTANCHÉITÉ
LI: EINLAGE | LINER | RONDELLE
PL: EINSATZ | PLUG | UTILISATION

Andere Verschlüsse auf Anfrage
Other closures on request
Autre bouchon sur demande

PUSH-PULL

	28/410
5	CO



2-TEILIG MIT RÜCKDREHSPERRE (KISI) CHILD SAFE CLOSURE | BOUCHON SÉCURITÉ ENFANT TESTÉ

	24/410	28/410	12,35 ECAP	20/410 ECAP
6	CO/PL	CO/LI/PL	PL	PL



PILZVERSCHLUSS MUSHROOM CLOSURE | FERMETURE CHAMPIGNON

	28/415	28-B408
7	CO/PL	CO/PL

individuelles Logo auf dunkler Version möglich
individual logo on dark version possible
logo individuel sur version sombre possible



SEIFENSPENDER DISPENSER | DISTRIBUTEUR DE SAVON

	24/410	28/410
8	LI	LI



**DICHTUNG
SEAL
JOINT**

CO: KONUSDICHTUNG | CONE | CÔNE D'ÉTANCHÉITÉ
LI: EINLAGE | LINER | RONDELLE
PL: EINSATZ | PLUG | UTILISATION

Andere Verschlüsse auf Anfrage
Other closures on request
Autre bouchon sur demande

FEINZERSTÄUBER SPRAYER I VAPORISATEUR

	20/ 410	24/ 410	24/ 415	28/ 410	GL18/ DIN18
	9	LI	LI	LI	LI



SPRÜHPISTOLE TRIGGER-SPRAY-PUMP I PISTOLET DE PULVÉRISATION

	28/410
	10 LI



25 MM SNAP-ON

	25 mm snap on
	11.1 CO

mit und ohne Membranventil
with and without membran valve
avec et sans membrane



25 MM SNAP-ON SQ-A MIT ORIGINALITÄT

25 MM SNAP-ON SQ-A WITH TAMPER EVIDENCE | 25 MM SNAP-ON SQ-A AVEC ORIGINALITÉ

	25 mm snap on
	11.2 CO

mit Membranventil
with membran valve
avec membrane



**DICHTUNG
SEAL
JOINT**

CO: KONUSDICHTUNG | CONE | CÔNE D'ÉTANCHÉITÉ
LI: EINLAGE | LINER | RONDELLE
PL: EINSATZ | PLUG | UTILISATION

Andere Verschlüsse auf Anfrage
Other closures on request
Autre bouchon sur demande

SCHRAUBVERSCHLUSS MIT SIEGELFOLIE UND MEMBRANVENTIL SCREW CAP WITH IHS LINER AND MEMBRANE VALVE | BOUCHON À VIS AVEC FILM DE SCELLAGE ET VALVE À MEMBRANE

	33-400	38-400	
	12	Siegel/seal	IHS-Liner



SCHRAUBVERSCHLUSS MIT ORIGINALITÄTSBAND (ANGEBUNDEN) SCREW-ON WITH TAMPER EVIDENCE (TETHERED) | BOUCHON VISSÉ AVEC INVIOIABILITÉ (ATTACHÉ)

	38 mm 2-start	38 mm 2-gang Hotfill	
	13	CO	LI



VERSCHLUSS MUNDSPÜLUNG MOUTHWASH-CLOSURE | BOUCHON BAINS DE BOUCHE

	28 mm MS 2-start	
	14	CO

Kindergesichert mit Originalitätsband
child-resistant with tamper evidence
sécurisée pour les enfants avec inviolabilité



Mit und ohne Kindersicherung erhältlich.
Available with and without child safety locks.
Disponible avec et sans sécurité enfants.

MICRO SQUEEZE MIT MEMBRANVENTIL | WITH MEMBRAN VALVE | AVEC MEMBRANE

	18 mm snap-on	
	15	CO



**DICHTUNG
SEAL
JOINT**

CO: KONUSDICHTUNG | CONE | CÔNE D'ÉTANCHÉITÉ
LI: EINLAGE | LINER | RONDELLE
PL: EINSATZ | PLUG | UTILISATION

Andere Verschlüsse auf Anfrage
Other closures on request
Autre bouchon sur demande

PREFORMS

PREFORMS
PRÉFORMES



20/410

 g	5,3 / 7 / 11 / 13 / 15
---	------------------------



24/410

 g	13 / 17 / 21 / 30 / 35
---	------------------------



28/410

 g	21 / 24 / 29,5 / 36 / 39 / 42 / 50
---	------------------------------------



38-400

 g	11 / 13 / 16 / 19 / 21 / 26 / 32
---	----------------------------------



ROPP28

 g	15 / 17,5 / 21 / 24 / 29
---	--------------------------



BVP28H38

 g	48
---	----



25 MM SNAP ON

 g	17 / 21 / 25
---	--------------



27 MM SNAP ON

 g	21 / 25,1
---	-----------



38 MM 2-START

 g	16 / 18 / 24 / 27 / 32,5
---	--------------------------



28 MM MS 2-START

 g	33
---	----



We make bottles.



Der Standort der **EPROPLAST** GmbH befindet sich im geografischen Zentrum von Deutschland. Das reduziert Transportwege und Kosten.

The location of **EPROPLAST** GmbH is geographically in the middle of Germany. This is reducing transport distances and costs.

Le site **EPROPLAST** se trouve géographiquement au centre de l'Allemagne. Ceci réduisant les distances et donc les coûts.



PLAST